

STARTER
Article Text
1994 Suzuki Swift
For Xeon

Copyright © 1998 Mitchell Repair Information Company, LLC
Tuesday, December 02, 2003 06:32PM

ARTICLE BEGINNING

1994 ELECTRICAL
Suzuki of America Corp. - Starters

Swift

DESCRIPTION

Two types of starter motors are used, conventional and reduction gear. Both types of starters consist of yoke assembly, armature assembly, overrunning clutch assembly, separate plunger-style solenoid (magnetic switch) assembly, drive end frame (housing), rear end frame (commutator end housing), brush holder and drive lever. Reduction gear type starter also has a reduction gear assembly combined with shock absorber mechanism.

With ignition in START position, solenoid is activated. Yoke engages starter pinion and overriding clutch assembly with flywheel gear and closes solenoid contacts, energizing starter motor. When engine starts, an overrunning clutch assembly protects armature from excessive speed until switch is opened. A return spring disengages pinion from flywheel gear..

TROUBLE SHOOTING

NOTE: See TROUBLE SHOOTING - BASIC PROCEDURES article in the GENERAL INFORMATION section.

BENCH TESTING

COMMUTATOR

Ground Test

Check for continuity between commutator and armature coil core. See Fig. 1. If continuity does not exist, armature is good. Proceed to OPEN CIRCUIT TEST. If continuity exists, armature is grounded. Replace armature.

Open Circuit Test

Check for continuity between individual segments of brush end of armature. See Fig. 2. If there is continuity between all segments, armature is good. If there is no continuity, there is an open circuit. Replace armature.

FIELD COIL

Using a volt/ohmmeter, check for continuity between brush and bare surface. See Fig. 3. If there is no continuity, field coil is good. If there is continuity, field coil is bad. Replace field coil.

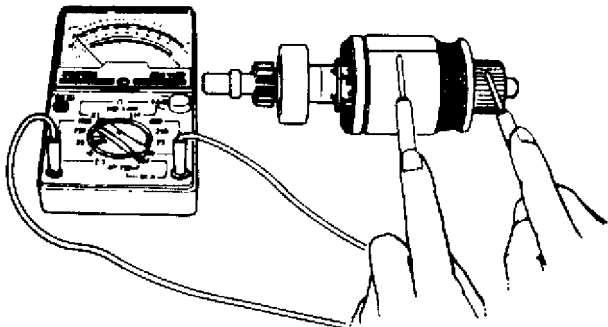

Fig. 1: Testing Armature For Grounds
Courtesy of Suzuki of America, Inc.

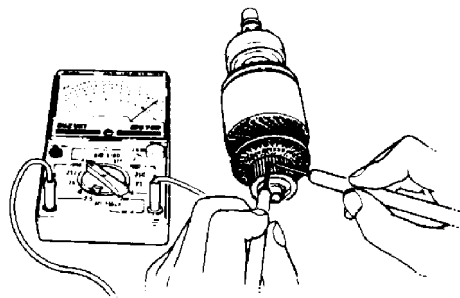

Fig. 2: Testing Armature For Opens
Courtesy of Suzuki of America, Inc.

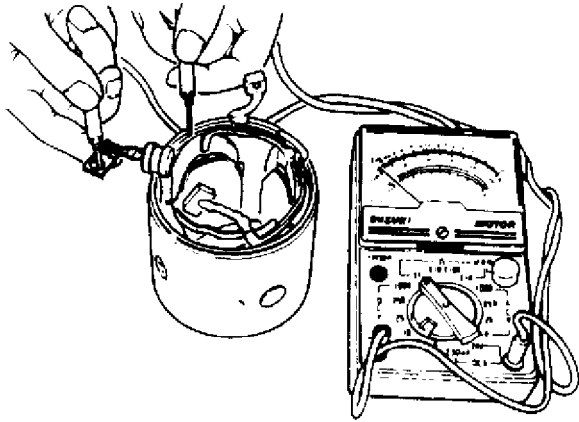

Fig. 3: Testing Field Coil Continuity
 Courtesy of Suzuki of America, Inc.

BRUSH HOLDER & SPRING

1) Check for smooth movement of brush in brush holder. If movement is sluggish, inspect holder for distortion and contamination. Clean, repair or replace as necessary.

2) Check for continuity across insulated (positive side) brush holder and grounded (negative side) brush holder. If there is no continuity, brush holder is good. If there is continuity, insulation is bad. Replace brush holder as an assembly.

SOLENOID

NOTE: Perform tests with starter assembled and field lead from starter disconnected at solenoid.

CAUTION: DO NOT engage starter solenoid for more than 3-5 seconds during testing or damage to coil winding may result.

Pull-In Coil Open Circuit Test

Using an ohmmeter, check for continuity between solenoid "S" and "M" terminals. If continuity is present, coil is good. If no continuity exists, replace solenoid.

Pull-In Test

Connect test leads to starter. See Fig. 4. Connect negative battery lead to starter housing and "M" terminal. Connect positive battery lead to "S" terminal. If starter pinion gear does not move out, replace solenoid.

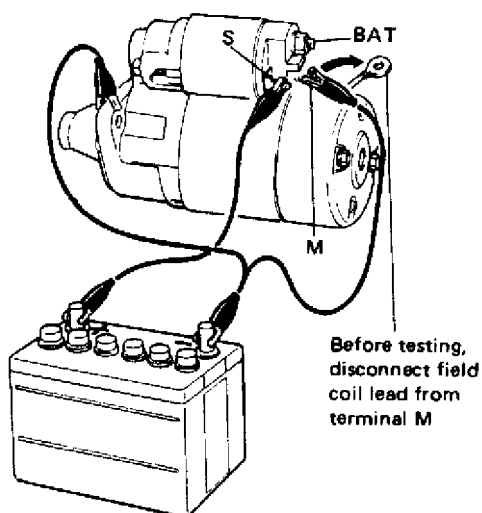

Fig. 4: Testing Solenoid Pull-In & Hold-In Coil Windings
 Courtesy of Suzuki of America Corp.

Hold-In Open Coil Circuit Test

Check for continuity between solenoid "S" terminal and solenoid housing. If continuity is present, coil is good. If continuity does not exist, replace solenoid.

Hold-In Test

Connect test leads to starter as in PULL-IN TEST. See Fig. 4. Disconnect negative lead from "M" terminal. Starter pinion gear should stay out. If pinion gear does not stay out, replace solenoid.

Pinion Gear Return Test

Connect test leads to starter as in PULL-IN TEST. See Fig. 4. Disconnect negative lead from starter housing. Starter pinion should

retract.

No-Load Performance Test

1) Using a jumper wire, connect battery negative terminal to starter housing. Connect positive battery terminal to ammeter. Connect other side of ammeter to starter "S" and BAT terminals. Ensure starter rotates smoothly.

2) On GT (A/T), starter current draw should be less than 90 amps at 11 volts. On GT (M/T), starter current draw should be less than 90 amps at 11.5 volts.

3) On all models using conventional type starter, starter current draw should be 50-75 amps at 11 volts.

REMOVAL & INSTALLATION

Removal

Disconnect negative battery cable from battery. Disconnect solenoid lead and battery cable from solenoid terminals. Remove 2 starter motor retaining bolts. Remove starter motor.

Installation

Install starter motor. Install and tighten 2 starter motor retaining bolts. Connect solenoid lead and battery cable to solenoid. Connect negative battery cable to battery.

OVERHAUL

DISASSEMBLY

1) Mark mating surfaces of starter housing and solenoid housing and starter housing and yoke for reassembly reference. Remove starter housing field coil lead from solenoid terminal. Remove 2 screws holding solenoid to starter housing. Remove solenoid.

NOTE: On conventional type starter, remove solenoid from starter housing by lifting up and out to release hook from pinion lever.

2) Loosen and remove 2 bolts and 2 screws holding commutator cover to starter housing. On conventional type starter, remove armature plate and brake spring. Remove commutator cover from yoke. Separate brush holder, armature and yoke from starter housing.

3) On reduction type starter, remove gasket and gears. Remove seal rubber and plate. Remove shaft assembly and lever. On all models, draw brushes from brush holder.

4) To remove overrunning clutch, pull pinion stop ring in toward clutch side. Remove snap ring using Snap Ring Pliers (09900-06107). Remove pinion stop ring, and slide off overrunning clutch. See Fig. 5. On reduction type starter, remove circlip and pull planetary carrier shaft from center bearing and shock absorber assembly.

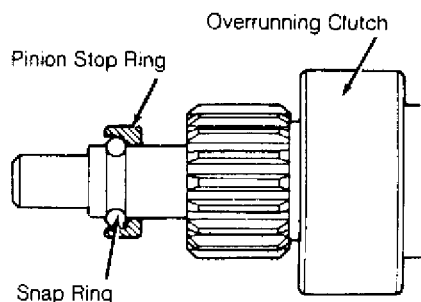

Fig. 5: Locating Snap Ring Under Pinion Stop Ring
Courtesy of Suzuki of America Corp.

INSPECTION

Armature Shaft Bushing

Inspect bushings for excessive scratching or other signs of wear. Check for signs of burning or other damage. Replace as necessary.

Brushes

1) Using a micrometer, measure brushes for wear. On GT (A/T)

and all other models with reduction type starters, standard measurement is .69" (17.5 mm). Minimum measurement is .47" (12 mm).

2) On GT (M/T) minimum measurement is .35" (9. mm). If less than minimum, replace brushes.

Brush Holder & Spring

1) Check for smooth movement of brush in brush holder. If movement is sluggish, inspect holder for distortion and/or contamination. Clean, repair or replace as necessary.

2) Inspect brush spring for wear, damage or other abnormal conditions. Using a spring tension gauge, check tension of brush spring. On GT (A/T), standard tension is 4.32 lbs. (1.96 kg) and minimum tension is 1.54 lbs. (0.7 kg). On standard models, standard tension is 4.63 lbs. (2.1 kg) and minimum tension is 1.54 lbs (0.7 kg). If tension is less than minimum specification, replace brush spring.

NOTE: On GT (M/T), replace brush holder and spring as an assembly.

Commutator

1) Inspect commutator for dirt or signs of burning. If dirt or burning is present, sand lightly with No. 300-400 sand paper or turn on lathe as necessary to clean surface.

2) Using a dial indicator, check commutator for runout. Standard runout is .0019" (.05 mm) or less. Maximum runout is .016" (.4 mm). If runout exceeds maximum limit, replace commutator.

3) Using a micrometer, measure diameter of brush end of commutator. On Swift and Swift GT (A/T), standard measurement is 1.14" (29 mm). Minimum measurement is 1.13" (28.8 mm). On all GT (M/T), minimum measurement is 1.06" (27 mm). If measurement is less than minimum, replace commutator.

4) Measure depth of insulator grooves between commutator segments. See Fig. 6. On Swift and Swift GT (A/T), standard depth is .0196-.031" (.5-.8 mm). Minimum depth is .0078" (.2 mm). On all GT (M/T), minimum depth is .0078" (.2 mm). If measurement is less than minimum depth, replace commutator.

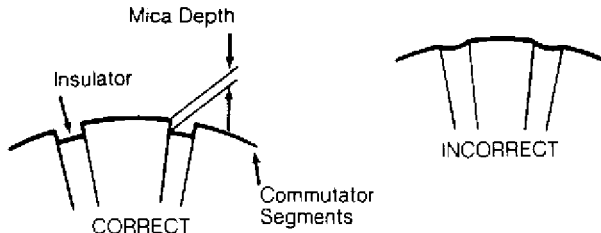

Fig. 6: Measuring Depth Of Commutator Segment Grooves
Courtesy of Suzuki of America Corp.

Drive Lever Yoke

Inspect all pivot points for excessive wear. If any pivot or engagement points show excessive wear, replace drive lever.

Pinion

1) Inspect pinion for wear or damage. Ensure clutch locks up when turned in direction of drive and rotates easily and smoothly in reverse direction. Replace as necessary.

2) Check teeth for wear or damage. Check pinion for smooth movement. Replace as necessary.

REASSEMBLY

1) Lubricate all friction surfaces. On reduction type starter, install center bearing and shock absorber assembly onto planetary carrier shaft, and install circlip. See Fig. 7. On all models, install overrunning clutch, pinion stop ring and snap ring (if removed). Install brushes into brush holder.

2) On reduction type starter, install shaft assembly and lever. Install seal rubber and plate. Install gasket and gears. On all models, install armature, yoke and brush holder into starter housing, matching reference marks scribed during disassembly. Place commutator cover over starter housing.

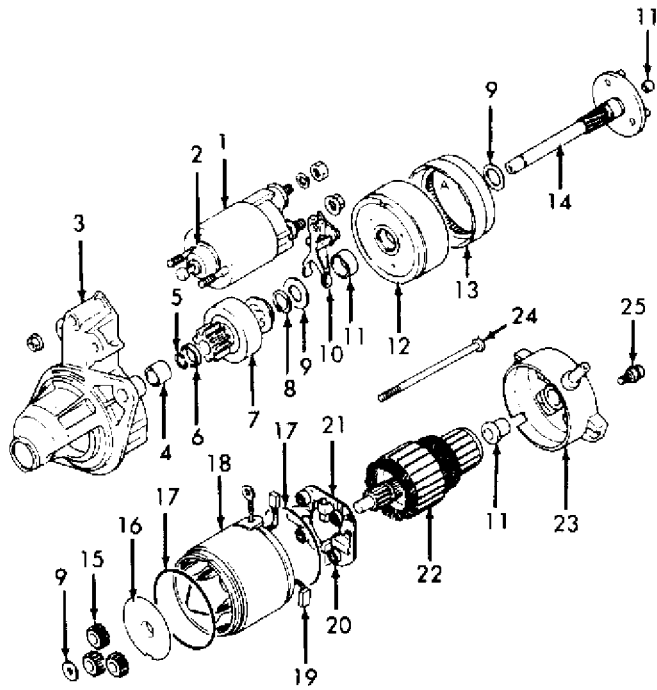

- | | |
|--|-------------------------------------|
| 1. Solenoid | 13. Internal Gear |
| 2. Boot | 14. Planetary Carrier Assembly |
| 3. Starter Housing | 15. Planetary Gear |
| 4. Needle Bearing | 16. Plate |
| 5. Snap Ring | 17. "O" Ring |
| 6. Pinion Stop Ring | 18. Yoke |
| 7. Overrunning Clutch Assembly | 19. Brush |
| 8. Circlip | 20. Brush Spring |
| 9. Washer | 21. Brush Holder Assembly |
| 10. Pinion Lever | 22. Armature |
| 11. Oilless Bearing | 23. Commutator End Housing Assembly |
| 12. Center Bearing & Shock Absorber Assembly | 24. Housing Bolt |
| | 25. Screw/"O" Ring |

Fig. 7: Exploded View Of Reduction Starter Motor
 Courtesy of Suzuki of America Corp.

3) On conventional type starter, install armature plate and brake spring. See Fig. 8. On all models, install 2 bolts and 2 screws holding commutator cover to starter housing. Align solenoid with scribe marks and install on starter housing.

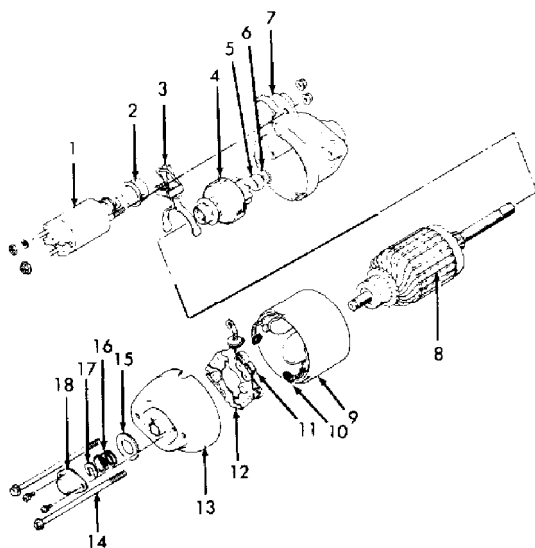

- | | |
|--------------------------------|-------------------------------------|
| 1. Solenoid | 10. Brush |
| 2. Boot | 11. Brush Spring |
| 3. Pinion Lever | 12. Brush Holder Assembly |
| 4. Overrunning Clutch Assembly | 13. Commutator End Housing Assembly |
| 5. Pinion Stop Ring | 14. Housing Bolt |
| 6. Snap Ring | 15. End Cap Gasket |
| 7. Starter Housing | 16. Armature Brake Spring |
| 8. Armature | 17. Armature Plate |
| 9. Yoke | 18. Commutator End Cap |

STARTER

ht © 1998 Mitchell Repair Information Company, LLCesda

Fig. 8: Exploded View Of Conventional Starter Motor
 Courtesy of Suzuki of America Corp.

4) Install and tighten 2 solenoid-to-starter housing screws. Install starter housing field coil lead-to-solenoid terminal and

tighten retaining nut.

ADJUSTMENTS

NEUTRAL SAFETY SWITCH

Automatic Transmission

Adjust shift lever neutral safety switch by moving switch in direction of arrow. See Fig. 9. Stop and secure switch when click is heard or felt.

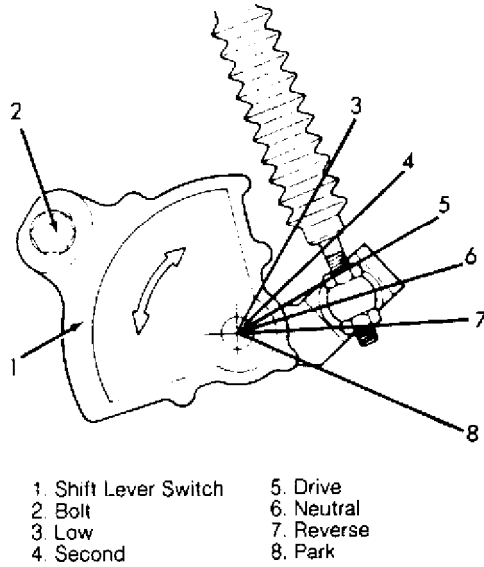
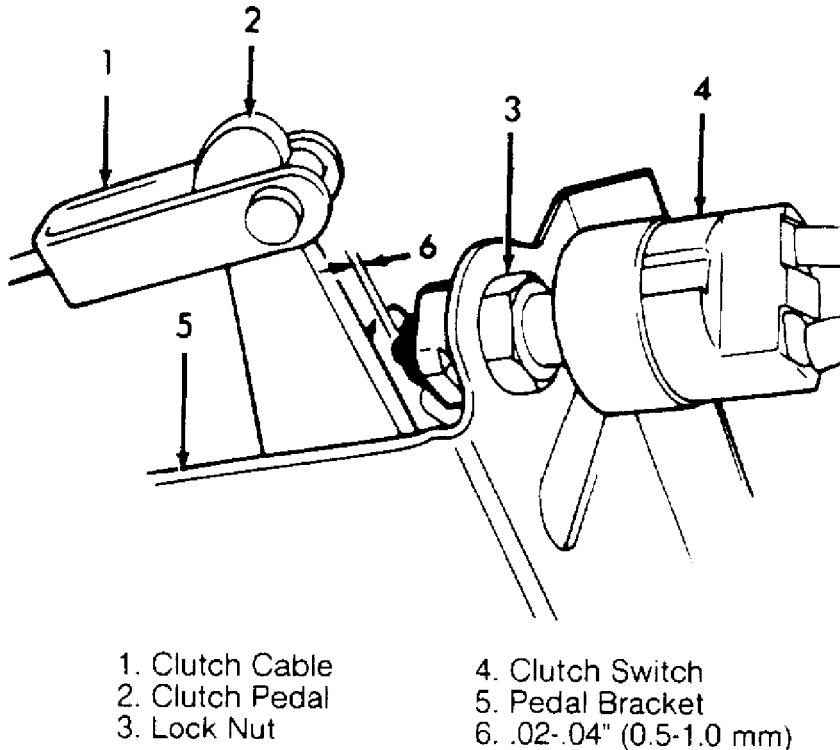

Fig. 9: Adjusting Neutral Safety Switch (A/T)
Courtesy of Suzuki of America Corp.

Manual Transmission

Adjust clutch neutral safety switch clearance between switch threaded end and clutch pedal at .02-.04" (0.5-1.0 mm). See Fig. 10.



92H01343

Fig. 10: Adjusting Neutral Safety Switch (M/T)
Courtesy of Suzuki of America Corp.

TORQUE SPECIFICATIONS

TORQUE SPECIFICATIONS

| Application | Ft. Lbs. (N.m) |
|-------------------------------|----------------|
| Clutch Switch Lock Nut | 7.4-11 (10-15) |
| Shift Lever Switch Bolt | 9.6-17 (13-23) |

| | | |
|-----------------------|-------|-----------------|
| Starter Housing Bolts | | |
| Except GT (M/T) | | 13-21 (18-28) |
| | | INCH Lbs. (N.m) |
| Field Lead Wire Nut | | |
| GT (M/T) | | 71-106 (8-12) |
| All Others | | (1) |
| Solenoid Nuts | | |
| GT (M/T) | | 53-97 (6-11) |
| All Others | | (1) |
| Starter Housing Bolts | | |
| GT (M/T) | | 44-62 (5-7) |

(1) - Specification is not available from manufacturer.

WIRING DIAGRAM

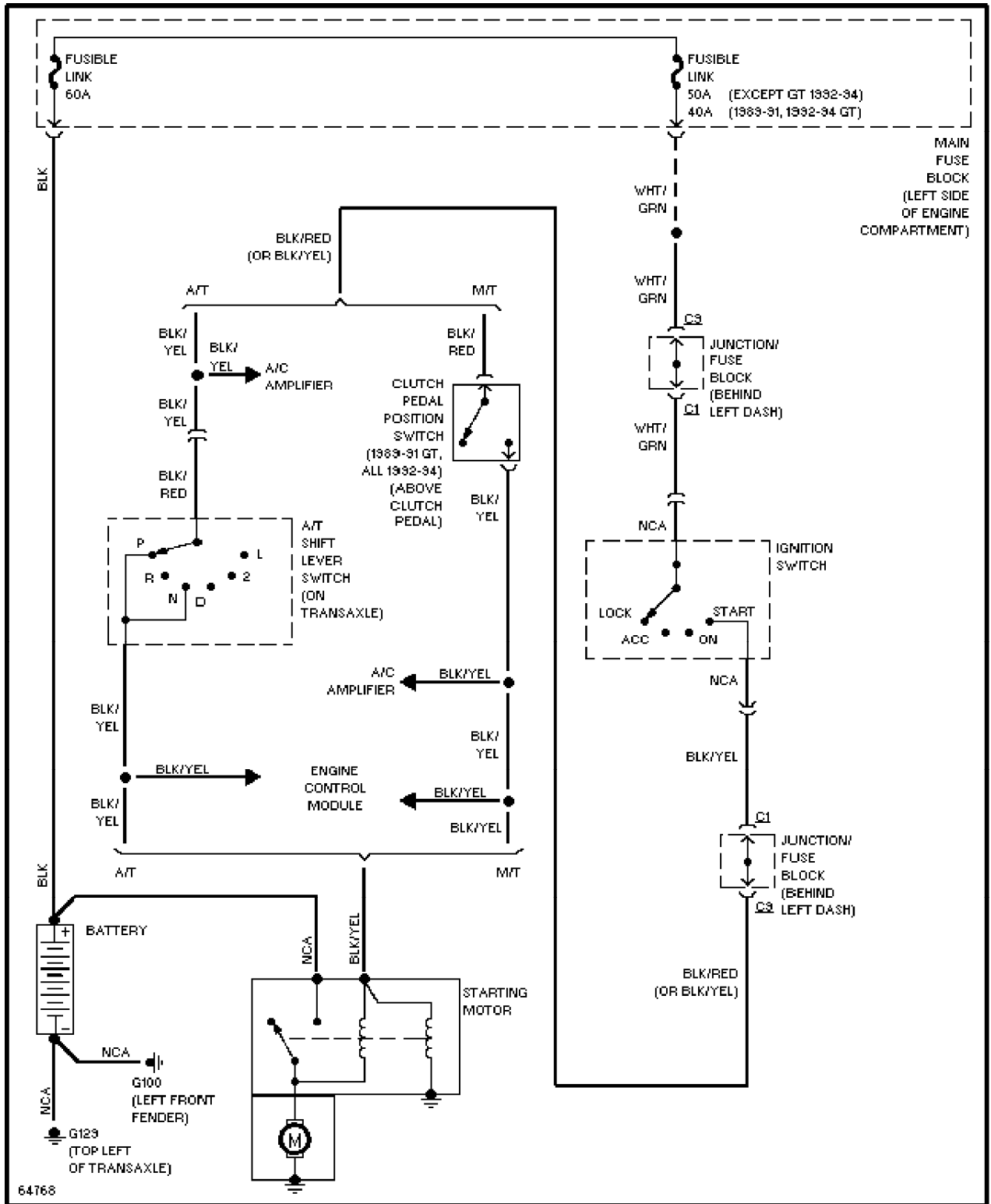

Fig. 11: Starting System Wiring Diagram

END OF ARTICLE